

**SERVICE MANUAL**

**1084S-P**

**JULY, 1988**

**PN-314890-01**

 **Commodore**

# SERVICE MANUAL

## 1084S-P

JULY, 1988

PN-314890-01

### **Commodore Business Machines, Inc.**

1200 Wilson Drive, West Chester, Pennsylvania 19380 U.S.A.

Commodore makes no express or implied warranties with regard to the information contained herein. The information is made available solely on an as is basis, and the entire risk as to completeness, reliability, and accuracy is with the user. Commodore shall not be liable for any damages in connection with the use of the information contained herein. The listing of any available replacement part herein does not constitute in any case a recommendation, warranty or guaranty as to quality or suitability of such replacement part. Reproduction or use without express permission, of editorial or pictorial content, in any matter is prohibited.

This manual contains copyrighted and proprietary information. No part of this publication may be reproduced, stored in a retrieval system, or transmitted in any form or by any means, electronic, mechanical, photocopying, recording or otherwise, without the prior written permission of Commodore Electronics Limited.

Copyright © 1988 by Commodore Electronics Limited.  
All rights reserved.

## IMPORTANT SAFETY NOTICE

Proper service and repair is important to the safe, reliable operation of all NAPCEC Equipment. The service procedures recommended by NAPCEC and described in this service manual are effective methods of performing service operations. Some of these service operations require the use of tools specially designed for the purpose. The special tools should be used when and as recommended.

It is important to note that this manual contains various **CAUTIONS** and **NOTICES** which should be carefully read in order to minimize the risk of personal injury to service personnel. The possibility exists that improper service methods may damage the equipment. It also is important to understand that these **CAUTIONS** and **NOTICES ARE NOT EXHAUSTIVE**. NAPCEC could not possibly know, evaluate and advise the service trade of all conceivable ways in which service might be done or of the possible hazardous consequences of each way. Consequently, NAPCEC has not undertaken any such broad evaluation. Accordingly, a servicer who uses a service procedure or tool which is not recommended by NAPCEC must first satisfy himself thoroughly that neither his safety nor the safe operation of the equipment will be jeopardized by the service method selected.

### WARNING

Critical components having special safety characteristics are identified with an **S** by the Ref. No. in the parts list and enclosed within a broken line\* along with the safety symbol  on the schematics or exploded views.

Use of substitute replacement parts which do not have the same specified safety characteristics may create shock, fire, or other hazards.

Under no circumstances should the original design be modified or altered without written permission from the N.A.P. Consumer Electronics Corp. NAPCEC assumes no liability, express or implied, arising out of any unauthorized modification of design. Servicer assumes all liability.

\* Broken line: — . — . — . — .

## INDEX

Description	Page
Adjustment Procedures .....	4-7
CRT P.C. Board (component side view) .....	22
Interconnect Diagram .....	7
Interface P.C. Board (component side view) .....	14, 22
Main P.C. Board (component side view) .....	9, 17
Power Supply P.C. Board (component side view) .....	15, 16
Replacement Parts List .....	23-25
Safety Notes .....	2, 26
Schematic Diagram .....	11-13, 19-21
Schematic Notes .....	10, 18
Specifications .....	2
Waveforms .....	8

## SPECIFICATIONS

CRT size	13 inch diagonal
CRT Deflection Angle	90 degrees
CRT Mask Pitch:	
-8CM505/CM8505/CM8705	0.65mm
-8CM515/8CM542/CM8562/CM8762	0.42mm
-8CM643	0.39mm
CRT Light Transmission:	
-CM8505/CM8705	56%
-8CM505/8CM515/8CM643	46%
-8CM542/CM8562/CM8762	46%
Power Requirements	115Vac/60Hz
Power Consumption	75W max.
Degaussing	Automatic (when switching on set)
Video Input Signals:	
CM8505/CM8705/8CM505/8CM515/8CM643	
	RGB analog 0.7, composite sync, 6 pin connector
Composite video	1Vp-p, negative sync, RCA connector RGB-1 TTL, separate horiz. and vert. sync, 8 pin connector
Horizontal Scanning Frequency	15734Hz
Horizontal Frequency Drift	1 % max.
Horizontal Flyback Time	12uS max.
Horizontal Blanking Time	12uS max.
Vertical Scanning Frequency	47-62.5Hz
Vertical Frequency Drift	1% max.
Vertical Flyback Time	0.95mS max.
Vertical Blanking Time	(21H) 1.33mS
RGB Amp Bandwidth	8MHz min.
RGB Amp Bandwidth (8CM643)	15MHz min.
Resolution:	
-Vertical	240 lines
-CM8505/CM8705 Horizontal	390 dots
-8CM505 Horizontal	390 dots
-8CM515/CM8562 Horizontal	640 dots
-8CM542/8CM643	690 dots
Character Display:	
-CM8505/CM8705	1000 characters (40 x 25)
-8CM505	1600 characters (64 x 25)
-8CM515/8CM542/CM8562/CM8762/8CM643	2000 characters (80 x 25)
Overshoot/Undershoot	5% max.
Black Level Shift	3% max.
Audio Input Signal	150mV eff.
Audio Input Impedance	10k
Audio Output Power	1W a 5% distortion
Audio Frequency Range	300Hz - 7kHz
Audio S/N Ratio	40dB min.
Operating Humidity Range	less than 80%
Dimensions (HxWxD)	320x350x387mm

\* Specifications subject to change without notice.

## ADJUSTMENT PROCEDURES

**Adjustment Notes:****unless otherwise specified:**

1. An isolation transformer must be used when servicing this unit.
2. Line voltage maintained at 120Vac, 60Hz.
3. The unit should be allowed to warm up for at least 30 minutes prior to making any adjustments.
4. Voltages measured with respect to ground.
5. Signal injection point is the Video In Jack.

**R496 Pincushion Adjustment (8CM643 only)**

1. Inject a cross-hatch pattern and set Brightness Control (R598) and Contrast Control (R585) to their mechanical centers.
2. Adjust R496 so that 14 blocks correspond to a width of 26cm.
3. Horizontal Amplitude and Centering Adjustment
4. Vertical Amplitude and Centering Adjustment

**R598 Sub-Brightness Control Adjustment (8CM643 only)****(Dual Trace Oscilloscope required)**

1. Inject a signal with a white raster to input connector.
2. Adjust G2 (R727) and Contrast Control to minimum. Adjust Brightness Control to mechanical center.
3. Connect a DC coupled probe from Channel A of the oscilloscope to pin 1 of IC502.
4. Connect a DC coupled probe from Channel B of the oscilloscope to the emitter of TS641.
5. Adjust the Sub-Brightness (R598) to place the top of the video signal (Channel A) at the same voltage level as the emitter of TS641 (Channel B).
6. Adjust Red (R705), Green (R705) and Blue (R706) cut off controls to set pins 6, 8, and 11 of Picture Tube at 100 volts each.
7. Advance G2 control (R727) until screen just begins to illuminate.
8. If the electron guns of the CRT are balanced, you should get a dull gray raster. However, if one color is more predominant than the others, adjust the cut-off controls of other 2 corresponding guns as required to obtain a gray raster.

**Power Supply Adjustment**

1. With the unit off, set the Volume Control (R316), Contrast Control (R585), and Brightness Control (R589) to minimum.
2. Preset R114 to mechanical center.
3. Connect a voltmeter across C494 and turn on the unit.
4. Adjust R114 for a reading of 125V on the meter.

**Horizontal Synchronization Adjustment**

1. Inject a cross-hatch pattern signal and short C434.
2. Adjust the horizontal sync with R437.
3. Remove the short from C434.

**Vertical Synchronization Adjustment**

1. Inject a cross-hatch pattern signal and short C434.
2. Adjust the vertical sync with R331.
3. Remove the short C434.

**Horizontal Amplitude and Centering Adjustment**

1. Inject a cross-hatch pattern signal and set the Brightness Control (R589) and Contrast Control (R585) to their mechanical centers.
2. Adjust R485 so that 14 blocks correspond to a width of 26cm.
3. Adjust R453 to center display horizontally.

**Vertical Amplitude and Centering Adjustment**

1. Inject a cross-hatch pattern and set the Brightness Control (R585) to their mechanical centers.
2. Adjust R353 so that 10 blocks correspond to a height of 18.5cm.
3. Adjust R364 to center the display vertically.

**Chrominance Adjustment****(Note: pin nos. in parenthesis indicate alternate 16-pin IC.)**

1. Inject a color bar pattern signal and adjust the secondary controls for normal viewing. Place SK3 (not used in CM8562, CM8762, 8CM542) in the off position.
2. Connect an oscilloscope to pin 15 of IC502 and adjust S533 for minimum amplitude of the chrominance signal that is present on the various brightness steps of the luminance signal.
3. Short pins 9 (3) and 17 (11) of IC501.
4. Adjust C567 to minimize the chroma as visible on the screen.
5. Remove the shorting clips from pins.

**Comb Filter Adjustment****(CM8505/CM8705/8CM505/8CM515/8CM643 ONLY)**

1. Inject a color bar pattern signal and place the Comb Filter Switch (SK3) in the on position.
2. Connect an oscilloscope to the emitter of TS531 and adjust R523 and S515 for minimum amplitude of the chrominance signal. For optimum performance, repeat the adjustment.

**Focus Adjustment**

1. Inject a cross-hatch pattern signal and set the Brightness Control (R589) to minimum and the Contrast control (R585) to maximum.
2. Adjust R732 for optimum focus.

**X-Ray Protection Circuit Adjustment**

1. Inject a color bar pattern signal and set the Brightness and Contrast Controls to minimum.
2. Connect a voltmeter between the wiper of R457 and ground.
3. Adjust R457 for a reading of 6.9V.

Note: The following adjustments need only be performed if the CRT has been replaced. Minor corrections for purity and convergence may be accomplished through the use of the Purity and Convergence Assembly located on the neck of the CRT.

**Color Purity Adjustment (Refer to Figure 1)**

1. Loosen the yoke clamp screw and slide the yoke back away from the rubber wedges.
2. Remove the rubber wedges (G) and slide the yoke forward until it rests firmly against the bell of the CRT.
3. Tighten the yoke clamp screw slightly so that the yoke can still be moved with some friction.
4. Place the multi-pole Purity and Convergence Assembly in the position shown in Figure 1.
5. Tighten screw (A) and turn securing ring (B) counter-clockwise. Position the unit so that it faces in an East/West direction and degauss the instrument.
6. Turn on the power and inject a cross-hatch pattern signal. Allow a 10 minute warm-up period.
7. Roughly adjust the static convergence, using tabs C and D.
8. Set the Vertical Centering Control (R364) to its mechanical center. Disconnect R723 and R724 to turn off the green and blue guns.

ADJUSTMENT PROCEDURES (Continued)

- Adjust the two-pole purity rings (E) to center the red vertical and horizontal lines.
- Inject a white pattern signal and move the deflection yoke to obtain a full red raster.
- Turn on the green and blue guns by reconnecting R723 and R724. If a uniformly white raster does not appear, minor adjustments may be made by adjusting the purity rings (E).
- Inject a cross-hatch pattern signal to ensure that the yoke is not tilted. If necessary, rotate the yoke to obtain a level raster.
- Tighten screw F and adjust R364 for proper vertical centering. Proceed to the Static Convergence Adjustment.

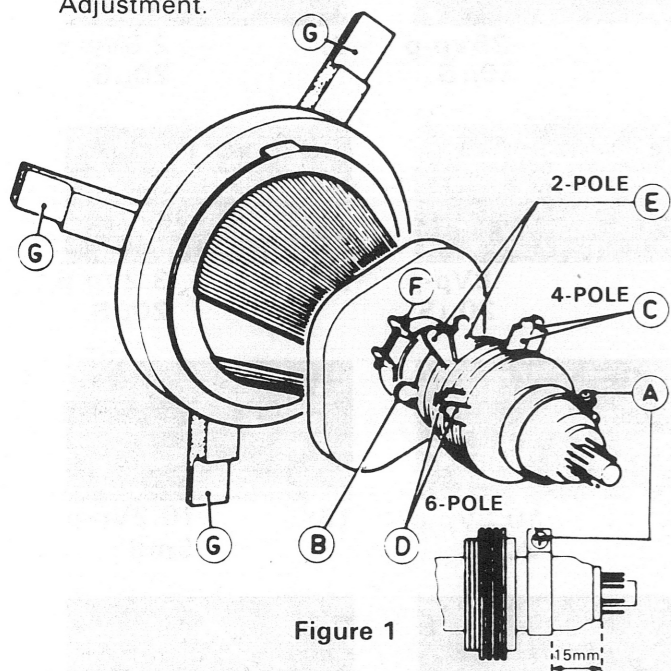

Figure 1

Static Convergence Adjustment

- Inject a cross-hatch pattern signal and allow a 10 minute warm-up period.
- Turn off the green gun by disconnecting R723. Turn locking ring (B) counterclockwise.
- Slowly spread, and if necessary, rotate the 4-pole magnetic rings (C) to converge red and blue lines at the center of the screen.
- Reconnect R723 to turn on the green gun and disconnect R724 to turn off the blue gun.
- Slowly spread, and if necessary, rotate the 6-pole magnetic rings (D) to converge the red and green lines at the center of the screen.
- Reconnect R724 to turn on the blue gun.
- For optimum performance, repeat steps 1 through 6. Proceed to the Dynamic Convergence Adjustment.

Dynamic Convergence Adjustment

- Inject a cross-hatch pattern signal and turn off the green gun by disconnecting R723.
- Tilt the yoke up and down to achieve the best convergence of the red and blue vertical lines at the 6 and 12 o'clock and the red and blue horizontal lines at the 3 and 9 o'clock positions (see Figure 2).
- When the correct position has been found, place a rubber wedge between the CRT. If the yoke is tilted up, place wedge 1 as shown in Figure 3a; if it is tilted down, place wedge 1 as shown in Figure 4a.
- Tilt the yoke to the left and right to find the point of best possible convergence of the red and blue lines

- at the edges, top, and bottom of the screen as shown in Figure 5.
- When the correct position is located, place wedges 2 and 3 as shown in Figure 3b or 4b.
- Remove wedge 1 and place it in the final position as shown in Figure 3c or 4c. Reconnect resistor R723 to turn on the green gun.

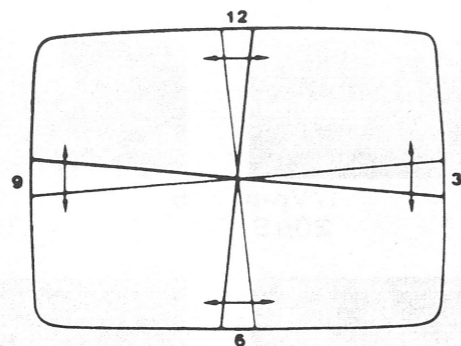

Figure 2 — Tilt yoke up or down to converge Red and Blue vertical lines at 6 and 12 o'clock positions, and Blue horizontal lines at 3 and 9 o'clock positions.

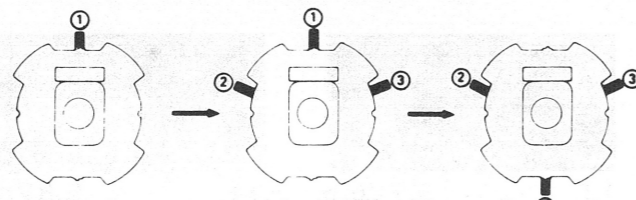

Figure 3a

Figure 3b

Figure 3c

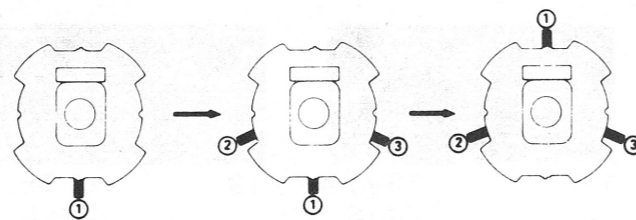

Figure 4a

Figure 4b

Figure 4c

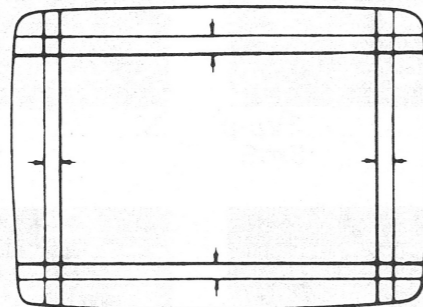

Figure 5 - Tilt yoke left or right to converge Red and Blue horizontal lines at the 6 and 12 o'clock positions, and Red and Blue vertical lines at the 3 and 9 o'clock positions.

Note: A computer delivering RGB TTL output (IBM or Apple) should be used to properly test the RGB circuitry. However, if a computer is not available, the following procedure may be used. EXCEPTION: CM8562/CM8762/8CM542 does not accept Analog RGB or X-RGB signals.

ADJUSTMENT PROCEDURES (Continued)

RGB INTERFACE P.C. BOARD CHECKS FOR ALL MODELS (Except CM8562/CM8762/8CM542)

Late Production RGB Interface models are IBM Compatible only after Feb. 87. Early Production models accept Apple (X-RGB) or IBM (RGB-1) prior to Feb. 2, 1987.

The purpose of this board is to accept RGB TTL signal inputs (RGB-I or X-RGB) and develop the R, G, and B signals in the monitor. By grounding the control input (Pin 1 of 8 pin Din Plug) the interface circuit will decode X-RGB to equal RGB-I signals in the monitor.

Interface P.C. Board Check

- If either Apple (X-RGB) or IBM (RGB-I) signals are available as a TTL input the interface operation in the other signal mode may be checked. By grounding the control input on each color the other mode will appear. Pins 2, 3, 4, and 5 the 8 Pin Din Jack are high level when open. Use the cross reference chart for this cross color check.
- To confirm proper operation of the RGB Interface Board, refer to the following truth table and ground the pins as shown. A voltmeter may be used to determine whether the output levels are high (1) or low (0). (Refer to schematic for pin nos.)
- Another quick check may be done using a sine or square wave generator. A 1 to 3 kHz square wave (2Vp-p) may be injected into the pins of the DIN jack in the truth table. Color flashes should be visible on the screen which correspond to the pin or pins connected to the signal generator. Pin 2 should give red flashes, pin 3 green flashes, etc. when in the IBM mode. The colors will vary when pin 1 is grounded along with any of the others because the Apple colors are not the same as the IBM colors.

APPLE TRUTH TABLE

INPUTS					OUTPUTS										
DIN PLUG PINS					IC272 PINS									IC271 PINS	
(I)	(B)	(G)	(R)	*	1	2	3	4	5	6	7	9	11	13	
0	0	0	0	0	0	0	0	0	0	0	0	0	0	0	
0	0	0	1	0	1	0	0	1	0	0	1	0	0	0	
0	0	1	0	0	0	1	0	0	0	0	0	1	0	1	
0	0	1	1	0	1	1	0	1	0	0	1	1	0	1	
0	1	0	0	0	0	0	0	0	1	0	0	0	1	0	
0	1	0	1	0	1	0	0	1	1	0	1	0	1	0	
0	1	1	0	0	0	1	0	0	1	0	0	1	1	1	
0	1	1	1	0	1	1	0	1	1	0	1	1	1	1	
1	0	0	0	0	0	0	1	0	0	1	0	0	0	0	
1	0	0	1	0	1	0	1	1	0	1	1	0	0	0	
1	0	1	0	0	0	1	1	0	0	1	0	1	0	1	
1	0	1	1	0	1	1	1	1	0	1	1	1	0	1	
1	1	0	0	0	0	0	1	0	1	1	0	0	1	0	
1	1	0	1	0	1	0	1	1	1	1	1	0	1	0	
1	1	1	0	0	0	1	1	0	1	1	0	1	1	1	
1	1	1	1	0	1	1	1	1	1	1	1	1	1	1	

\* IBM/APPLE switching line. (open=IBM; ground=APPLE)

RGB-TTL INPUTS (8 PIN DIN) Color Decoding Chart

Levels shown are with monitor driven by computer.

	Pin				
APPLE X-RGB	5	4	3	2	IBM RGB-I
BLACK	0	0	0	0	BLACK
MAGENTA	0	0	0	1	RED
DARK BLUE	0	0	1	0	GREEN
PURPLE	0	0	1	1	BROWN
DARK GREEN	0	1	0	0	BLUE
GREY 1	0	1	0	1	MAGENTA
MIDDLE BLUE	0	1	1	0	CYAN
LIGHT BLUE	0	1	1	1	WHITE
BROWN	1	0	0	0	GREY
ORANGE	1	0	0	1	LIGHT RED
GREY 2	1	0	1	0	LIGHT GREEN
PINK	1	0	1	1	LIGHT YELLOW
GREEN	1	1	0	0	LIGHT BLUE
YELLOW	1	1	0	1	LIGHT MAGENTA
AQUA	1	1	1	0	LIGHT CYAN
WHITE	1	1	1	1	INTENSIFIED WHITE

TTL Levels

Low (0) = Zero to .8 volts  
High (1) = 2.4 to 5 volts

Pin 1 is Apple/IBM Control Line  
Low (0) = Apple, High (1) = IBM Colors

Apple is a registered trademark of Apple Computers

IBM TRUTH TABLE

INPUTS					OUTPUTS										
DIN PLUG PINS					IC272 PINS									IC271 PINS	
(I)	(B)	(G)	(R)	*	1	2	3	4	5	6	7	9	11	13	
0	0	0	0	1	0	0	0	0	0	0	0	0	0	0	
0	0	0	1	1	1	1	1	0	0	0	0	0	0	0	
0	0	1	0	1	0	0	0	1	1	1	0	0	0	1	
0	0	1	1	1	1	1	1	0	1	0	0	0	0	1	
0	1	0	0	1	0	0	0	0	0	0	1	1	1	0	
0	1	0	1	1	1	1	1	0	0	0	1	1	1	0	
0	1	1	0	1	0	0	0	1	1	1	1	1	1	1	
0	1	1	1	1	1	1	1	1	1	1	1	1	1	1	
1	0	0	0	1	0	0	0	0	0	0	0	0	0	0	
1	0	0	1	1	1	1	1	0	0	0	0	0	0	0	
1	0	1	0	1	0	0	0	1	1	1	0	0	0	1	
1	0	1	1	1	1	1	1	1	1	1	0	0	0	1	
1	1	0	0	1	0	0	0	0	0	0	1	1	1	0	
1	1	0	1	1	1	1	1	0	0	0	1	1	1	0	
1	1	1	0	1	0	0	0	1	1	1	1	1	1	1	
1	1	1	1	1	1	1	1	1	1	1	1	1	1	1	

IBM is a registered trademark of International Business Machines

ADJUSTMENT PROCEDURES (Continued)

RGB 8 and 6 Pin DIN Sockets

PIN ASSIGNMENTS

PIN NO.	TTL INPUT 8 PIN SIGNAL	ANALOG 6 PIN SIGNAL
*1	IBM Open/Apple Gnd.	Green
2	Red	Horiz. Sync
3	Green	Ground
4	Blue	Red
5	Intensity	Blue
6	Ground	Vert. Sync
7	Horiz. Sync	
8	Vert. Sync	

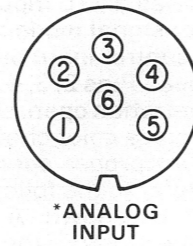
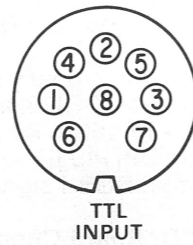

When using these sockets before connecting the equipment, place the RGB/Composite Switch in the RGB position.

\*Not used in CM8562/CM8762/8CM542

INTERCONNECT DIAGRAM

Note: To Remove Power Board Depress Locking Clip Located on Bottom of Cabinet Beneath Power Board.

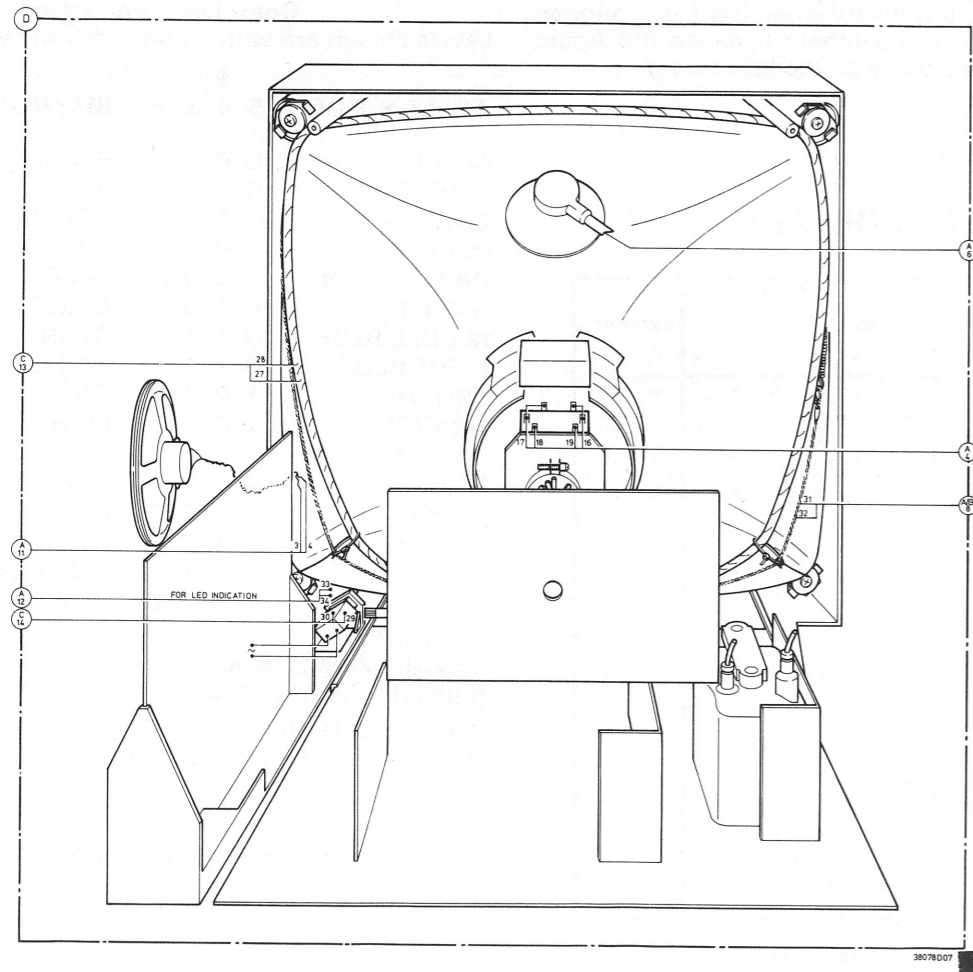

WAVEFORMS

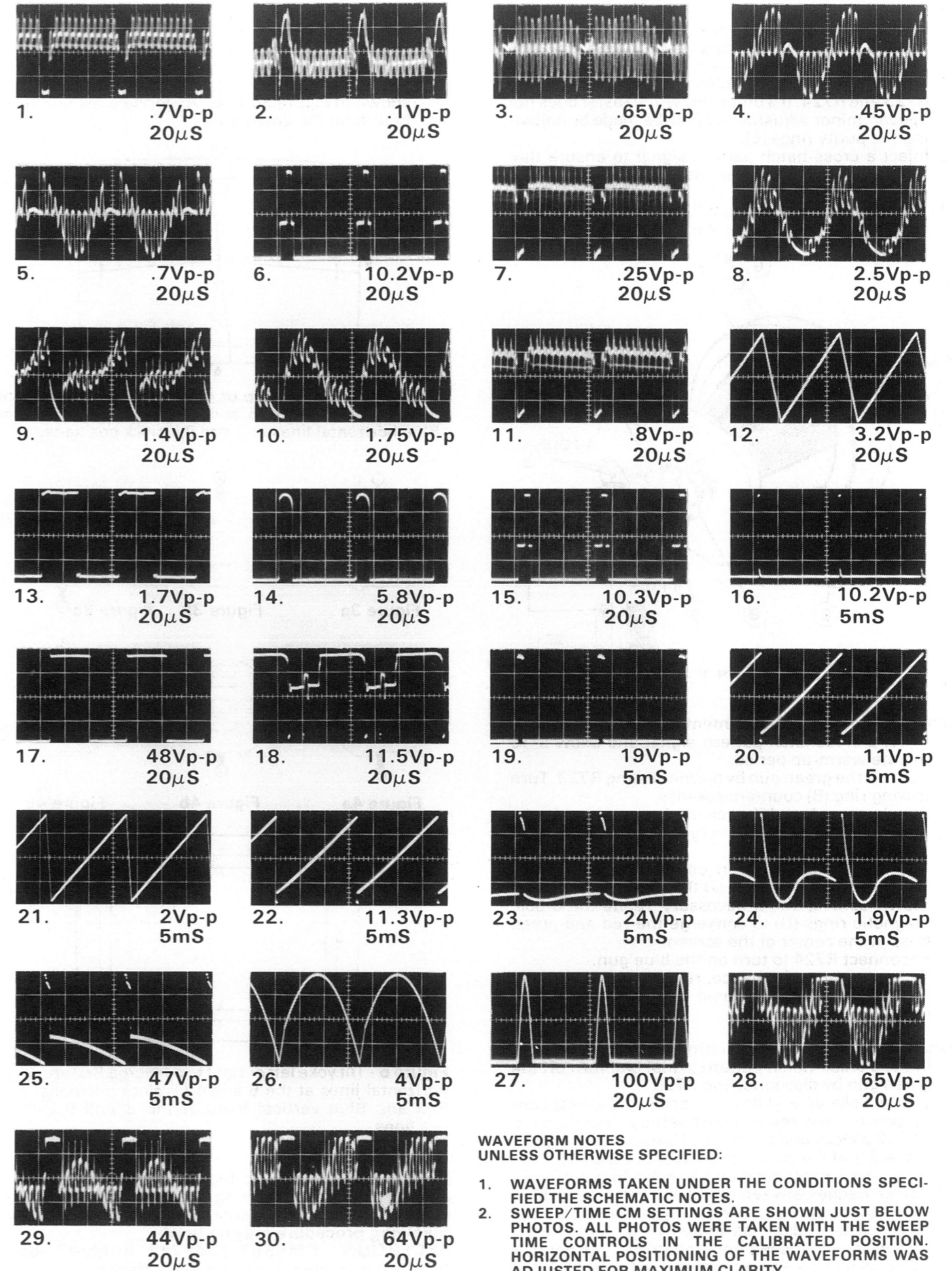

**WAVEFORM NOTES**  
UNLESS OTHERWISE SPECIFIED:

1. WAVEFORMS TAKEN UNDER THE CONDITIONS SPECIFIED THE SCHEMATIC NOTES.
2. SWEEP/TIME CM SETTINGS ARE SHOWN JUST BELOW PHOTOS. ALL PHOTOS WERE TAKEN WITH THE SWEEP TIME CONTROLS IN THE CALIBRATED POSITION. HORIZONTAL POSITIONING OF THE WAVEFORMS WAS ADJUSTED FOR MAXIMUM CLARITY.

### 8CM505/8CM515/8CM643/CM8505/CM8705 MAIN P.C. BOARD (viewed from component side)

NOTE: When IC501 has 16 Pin IC the following parts are not used; R550, R559, R561 & C568

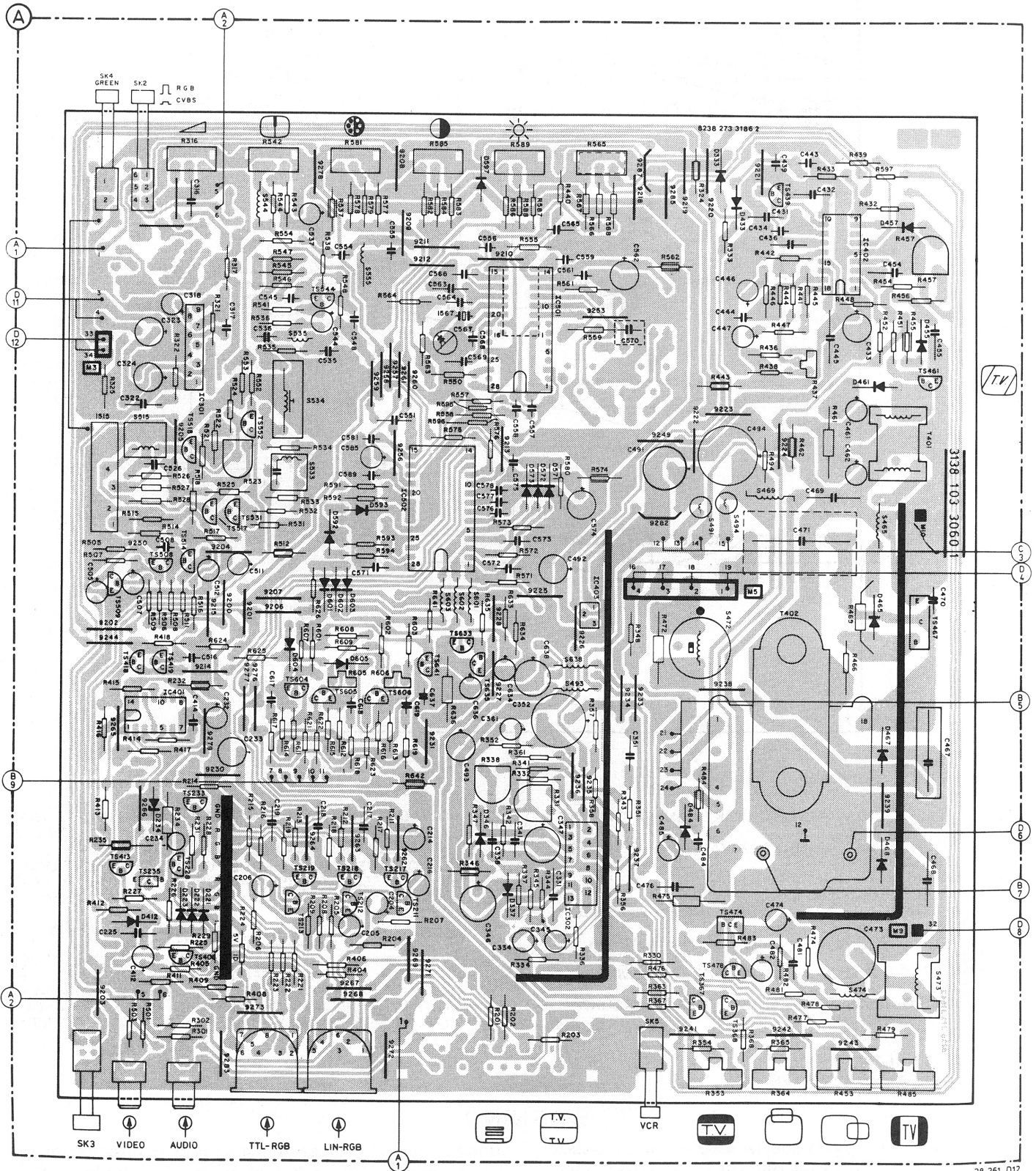



## INTERFACE SCHEMATIC DIAGRAM (Late Production Version)

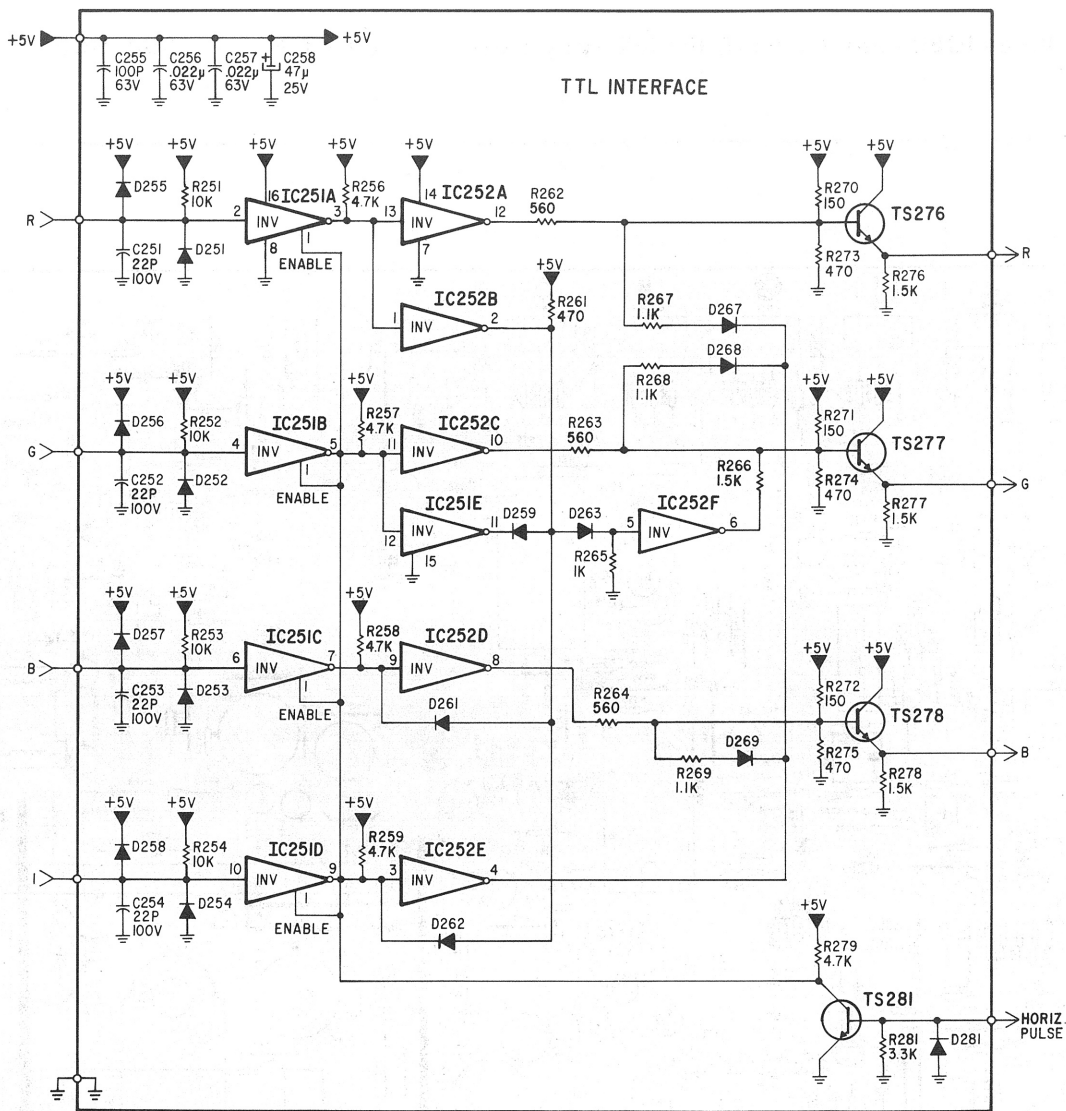

### SCHEMATICS NOTES: UNLESS OTHERWISE SPECIFIED:

- ALL VOLTAGES AND WAVEFORMS TAKEN UNDER THE FOLLOWING CONDITIONS:
  - LINE VOLTAGE MAINTAINED AT 120VAC, 60Hz VIA AN ISOLATION TRANSFORMER.
  - CUSTOMER CONTROLS SET AS FOLLOWS:
    - VOLUME CONTROL (R316) SET TO MINIMUM.
    - COLOR CONTROL (R581) SET FOR 8.75VDC WIPER TO GROUND.
    - CONTRAST CONTROL (R585) SET FOR 8.7VDC WIPER TO GROUND.
    - BRIGHTNESS CONTROL (R589) SET FOR 5VDC WIPER TO GROUND.
    - HUE CONTROL (R565) SET FOR 6VDC WIPER TO GROUND.
    - SK2 IN CVBS POSITION.
    - SK3, SK4 & SK5 OFF.

E.P. REFERS TO EARLY PRODUCTION  
L.P. REFERS TO LATE PRODUCTION

- VOLTAGES AND WAVEFORMS WERE TAKEN USING A 10 BAR GATED RAINBOW PATTERN SIGNAL SET TO DELIVER CHROMA BARS OF .5Vp-p AT THE VIDEO IN JACK.
- ALL VOLTAGES ARE POSITIVE DC WITH RESPECT TO GROUND, BE IT THE ISOLATED (SIGNAL) GROUND OR THE AC (HOT) GROUND WHICHEVER IS PRESENT IN THAT AREA OF CIRCUITRY.
- VOLTAGES MAY VARY DUE TO NORMAL PRODUCTION TOLERANCES. VOLTAGE SOURCES ARE ALSO NOMINAL.
- RESISTORS ARE ALL 5%, 1/4W, CARBON FILM EXCEPT FOR SOME UNIQUE PARTS. REFER TO REPLACEMENT PARTS LIST.
- CAPACITOR VALUES ARE IN MICROFARADS & PICOFARADS. REFER TO SCHEMATIC DIAGRAM FOR VALUES AND VOLTAGES EXCEPT FOR UNIQUE PARTS SHOWN IN REPLACEMENT PARTS LIST.

## WARNING

Critical components having special safety characteristics are identified with an **S** by the Ref. No. in the parts list and enclosed within a broken line\* along with the safety symbol  on the schematics or exploded views.

Use of substitute replacement parts which do not have the same specified safety characteristics may create shock, fire, or other hazards.

Under no circumstances should the original design be modified or altered without written permission from the N.A.P. Consumer Electronics Corp. NAPCEC assumes no liability, express or implied, arising out of any unauthorized modification of design. Servicer assumes all liability.

\* Broken line: 

8CM505/8CM515/8CM643/CM8505/CM8705 SCHEMATIC DIAGRAM

(Parts List - Pgs. 23, 24, 25)

CAUTION: USE A SEPARATE ISOLATION TRANSFORMER FOR THIS UNIT WHEN SERVICING.

INDICATES "HOT" GROUND.  
INDICATES ISOLATED SIGNAL GROUND.

NOTE: IC501 Alternate 16 Pin IC, see Insert page 18

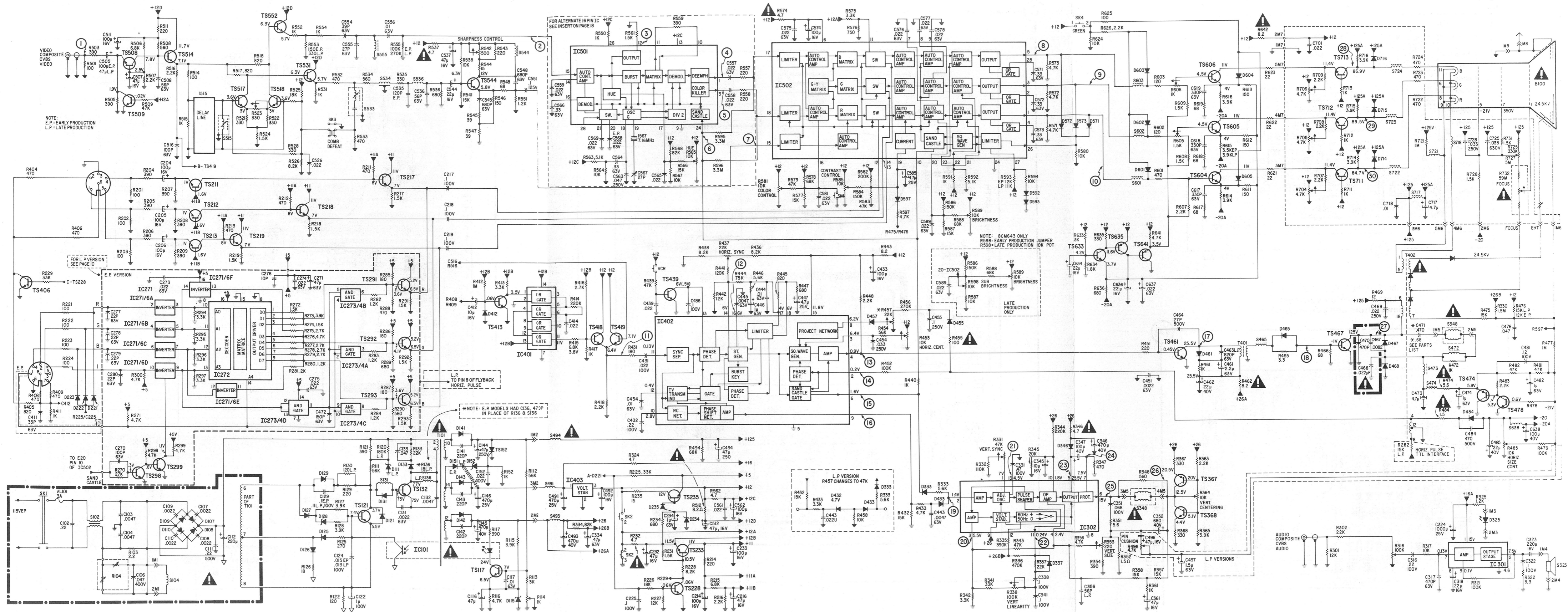

8CM505/8CM515/8CM643/CM8505/CM8705 RGB INTERFACE P.C. BOARD  
 (Early Production Version)  
 (viewed from component side)

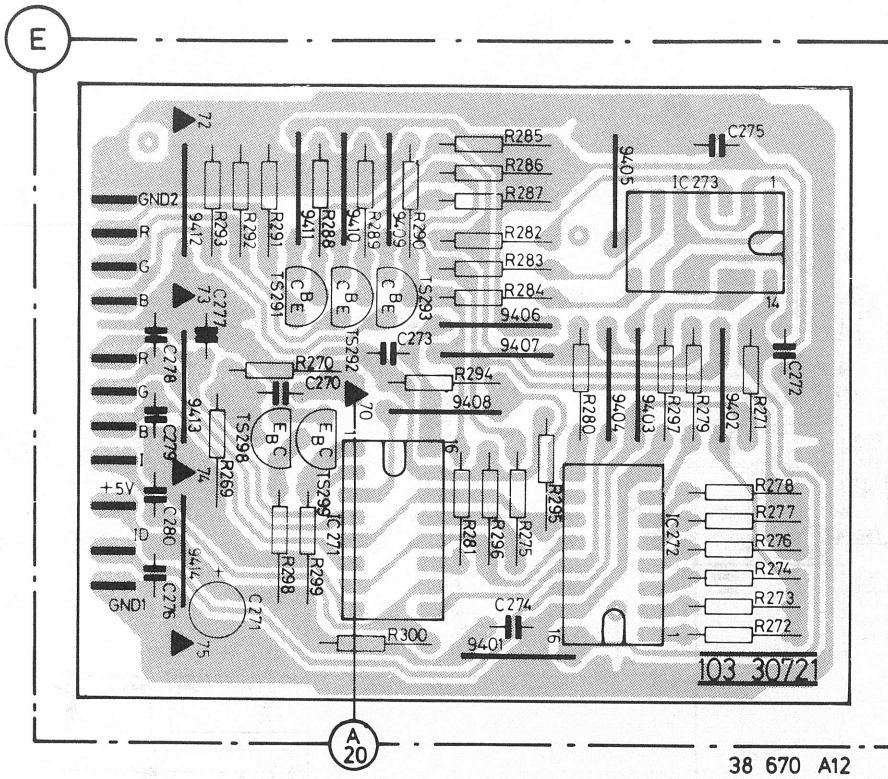

INTERFACE P.C. BOARD  
 (Late Production Versions)  
 (viewed from component side)

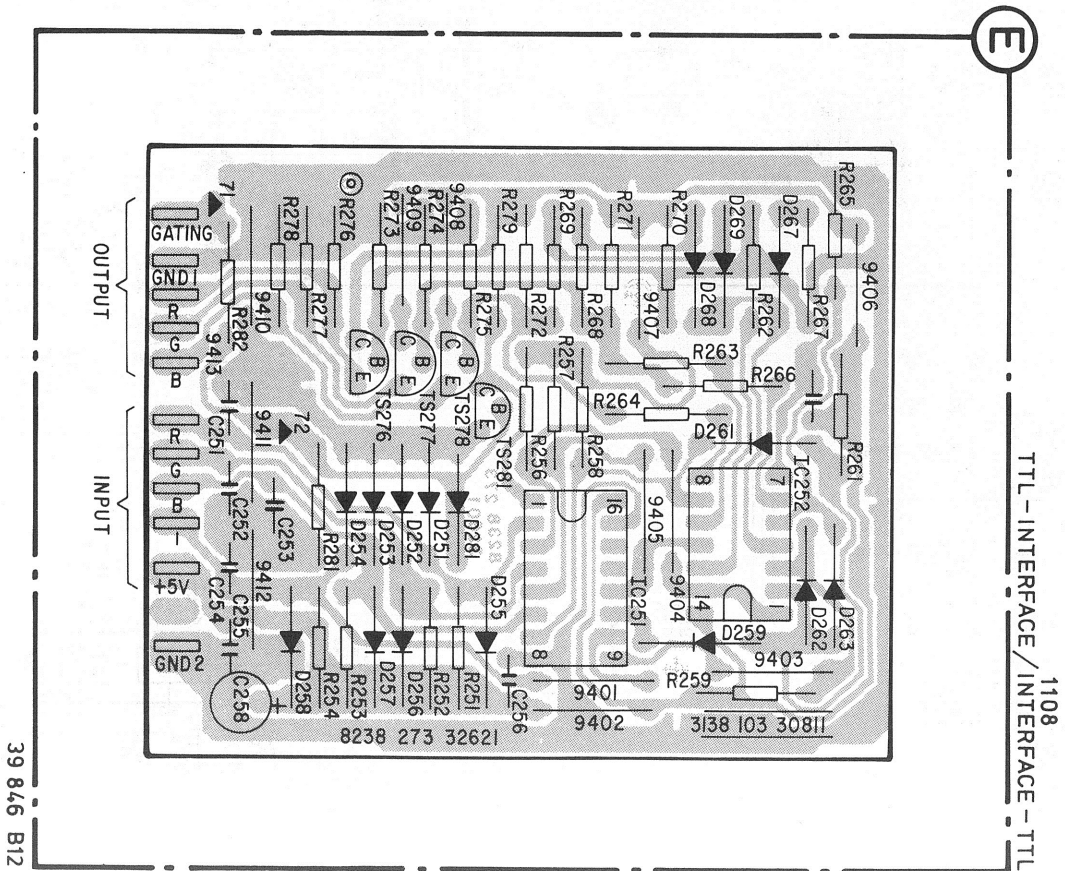

TTL - INTERFACE / INTERFACE - TTL

POWER SUPPLY P.C. BOARD (Late Production Version)  
(viewed from component side)

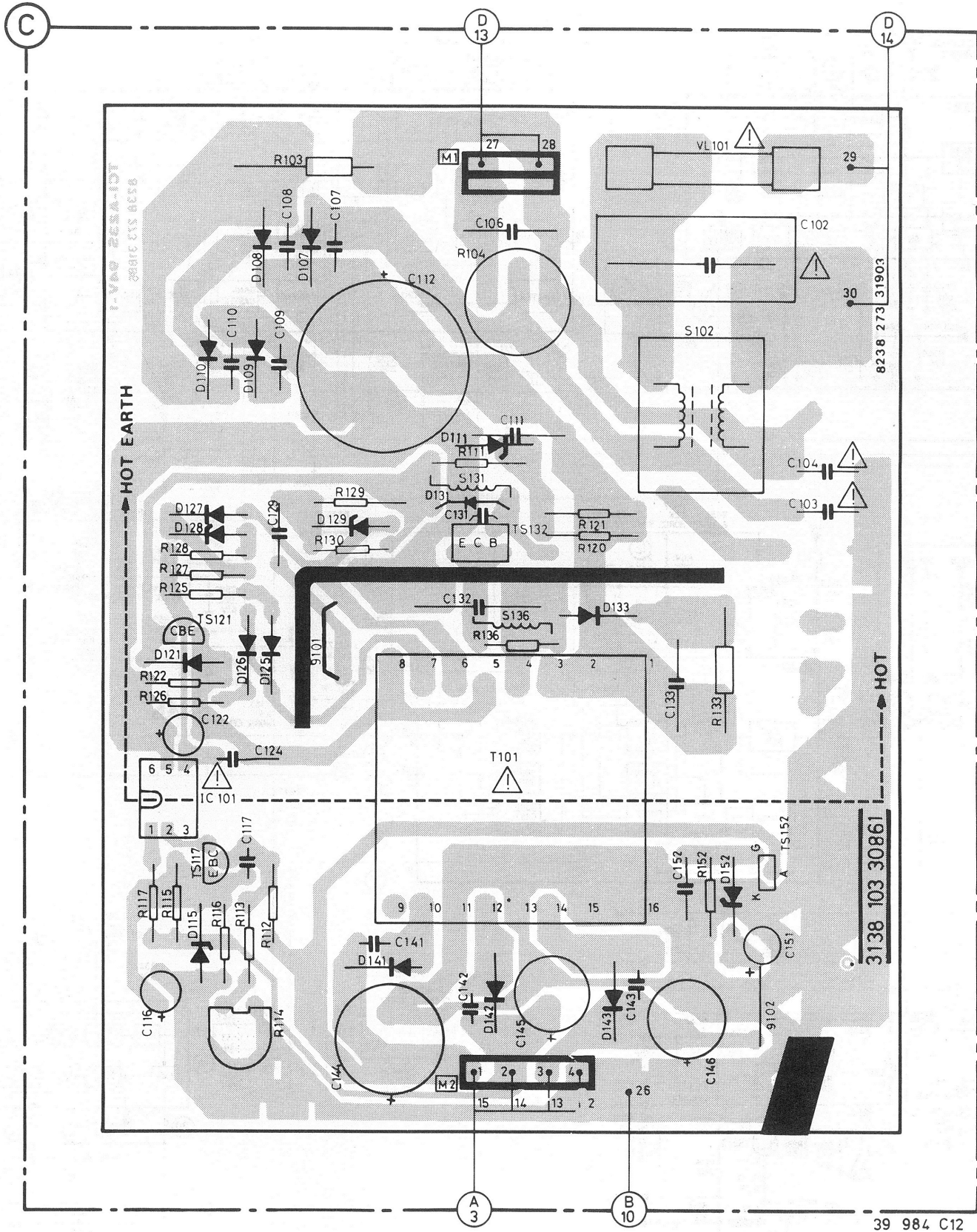

POWER SUPPLY P.C. BOARD (Early Production Version)  
(viewed from component side)

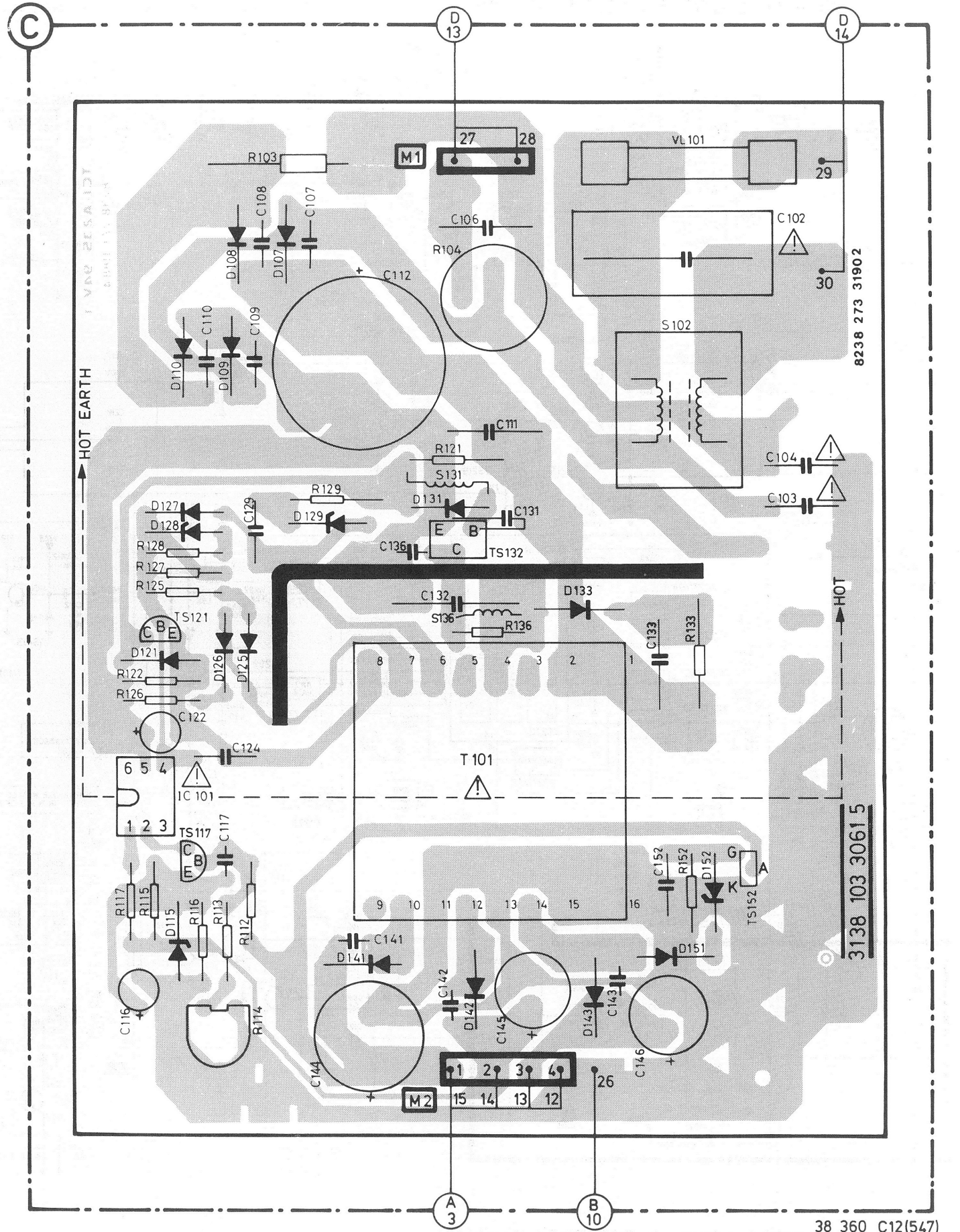

# 8CM542/CM8562/CM8762 MAIN P.C. BOARD (viewed from component side)

NOTE: When IC501 has 16 Pin IC the following parts are not used; R550, R559, R561 & C568

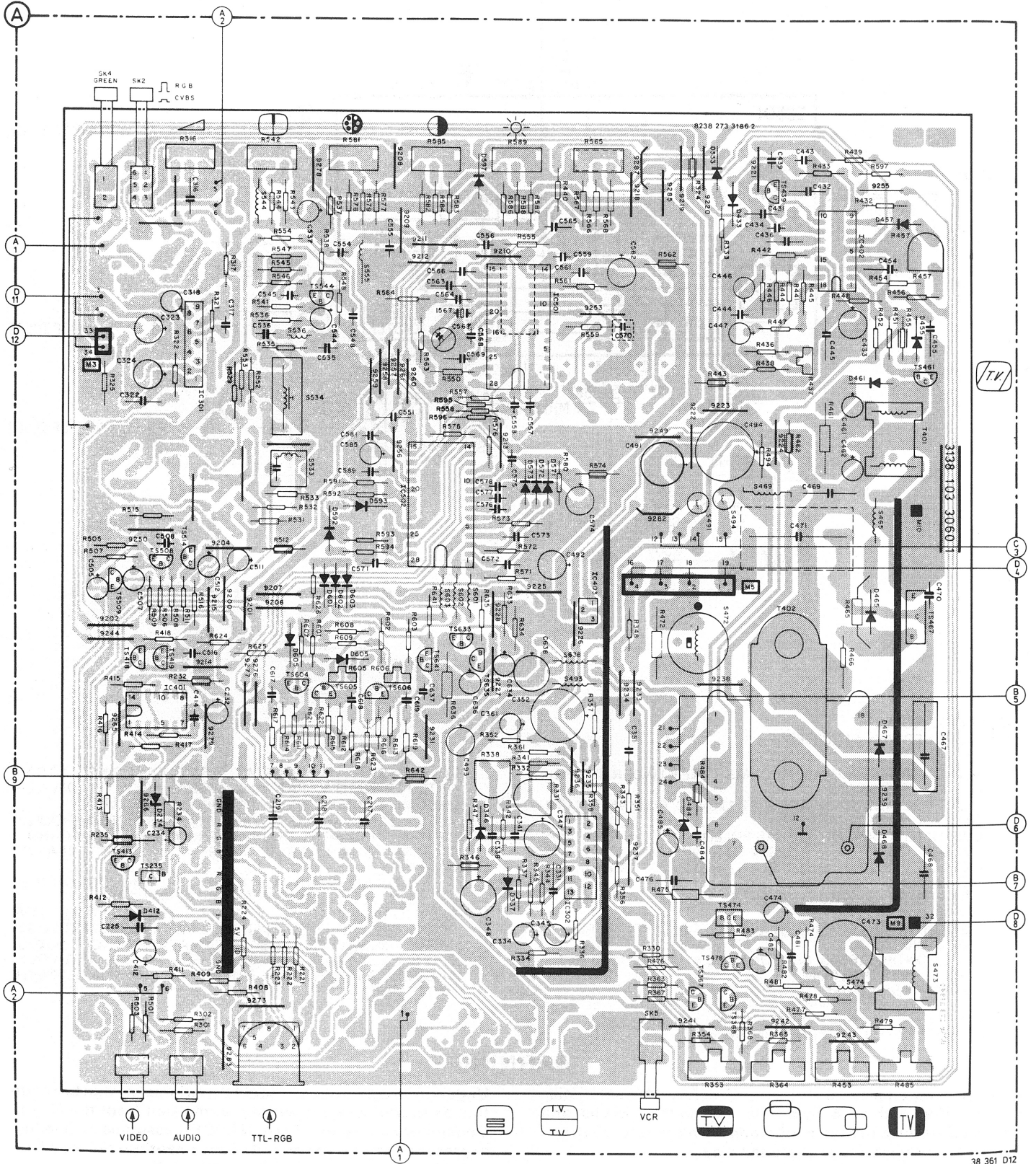

## IC501 ALTERNATE 16 PIN IC

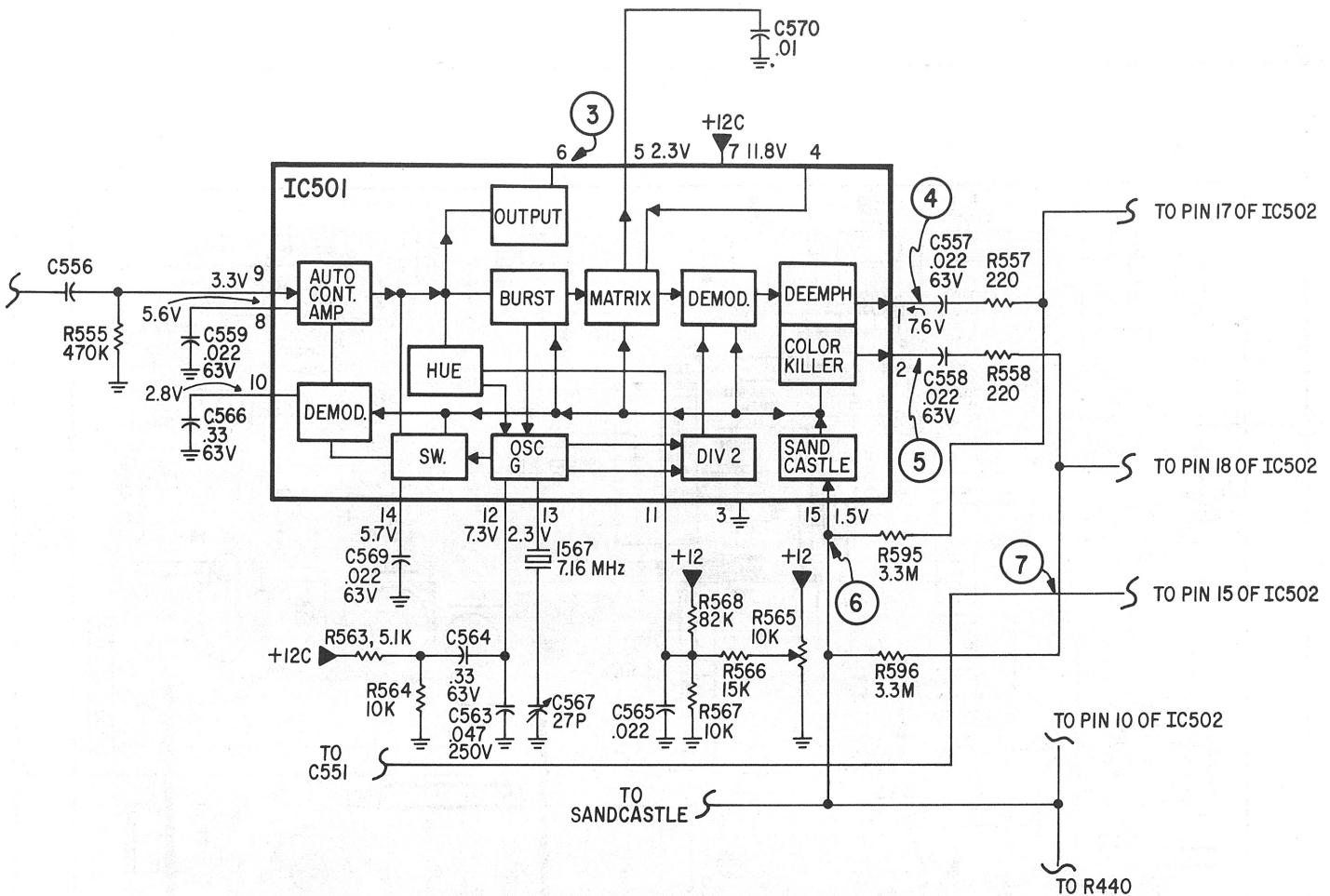
SCHEMATIC NOTES  
UNLESS OTHERWISE SPECIFIED:

- ALL VOLTAGES AND WAVEFORMS TAKEN UNDER THE FOLLOWING CONDITIONS:
  - LINE VOLTAGE MAINTAINED AT 120VAC, 60Hz VIA AN ISOLATION TRANSFORMER.
  - CUSTOMER CONTROLS SET AS FOLLOWS:
    - VOLUME CONTROL (R316) SET TO MINIMUM.
    - COLOR CONTROL (R581) SET FOR 8.75VDC WIPER TO GROUND.
    - CONTRAST CONTROL (R585) SET FOR 8.7VDC WIPER TO GROUND.
    - BRIGHTNESS CONTROL (R589) SET FOR 5VDC WIPER TO GROUND.
    - HUE CONTROL (R565) SET FOR 6VDC WIPER TO GROUND.
    - SK2 IN CVBS POSITION.
    - SK3, SK4 & SK5 OFF.

- VOLTAGES AND WAVEFORMS WERE TAKEN USING A 10 BAR GATED RAINBOW PATTERN SIGNAL SET TO DELIVER CHROMA BARS OF .5Vp-p AT THE VIDEO IN JACK.
- ALL VOLTAGES ARE POSITIVE DC WITH RESPECT TO GROUND, BE IT THE ISOLATED (SIGNAL) GROUND OR THE AC (HOT) GROUND WHICHEVER IS PRESENT IN THAT AREA OF CIRCUITRY.
- VOLTAGES MAY VARY DUE TO NORMAL PRODUCTION TOLERANCES. VOLTAGE SOURCES ARE ALSO NOMINAL.
- RESISTORS ARE ALL 5%, 1/4W, CARBON FILM EXCEPT FOR SOME UNIQUE PARTS. REFER TO REPLACEMENT PARTS LIST.
- CAPACITOR VALUES ARE IN MICROFARADS & PICO FARADS. REFER TO SCHEMATIC DIAGRAM FOR VALUES AND VOLTAGES EXCEPT FOR UNIQUE PARTS SHOWN IN REPLACEMENT PARTS LIST.

E.P. REFERS TO EARLY PRODUCTION  
L.P. REFERS TO LATE PRODUCTION

**WARNING**

Critical components having special safety characteristics are identified with an **S** by the Ref. No. in the parts list and enclosed within a broken line\* along with the safety symbol **⚠** on the schematics or exploded views.

Use of substitute replacement parts which do not have the same specified safety characteristics may create shock, fire, or other hazards.

Under no circumstances should the original design be modified or altered without written permission from the N. A. P. Consumer Electronics Corp. NAPCEC assumes no liability, express or implied, arising out of any unauthorized modification of design. Servicer assumes all liability.

\* Broken line: — . — . — . — . — . — .

8CM542/CM8562/CM8762 SCHEMATIC DIAGRAM

(Parts List - Pgs. 23, 24, 25)

CAUTION: USE A SEPARATE ISOLATION TRANSFORMER FOR THIS UNIT WHEN SERVICING.

INDICATES "HOT" GROUND. INDICATES ISOLATED SIGNAL GROUND.

NOTE: IC501 Alternate 16 Pin IC, See Insert Page 18

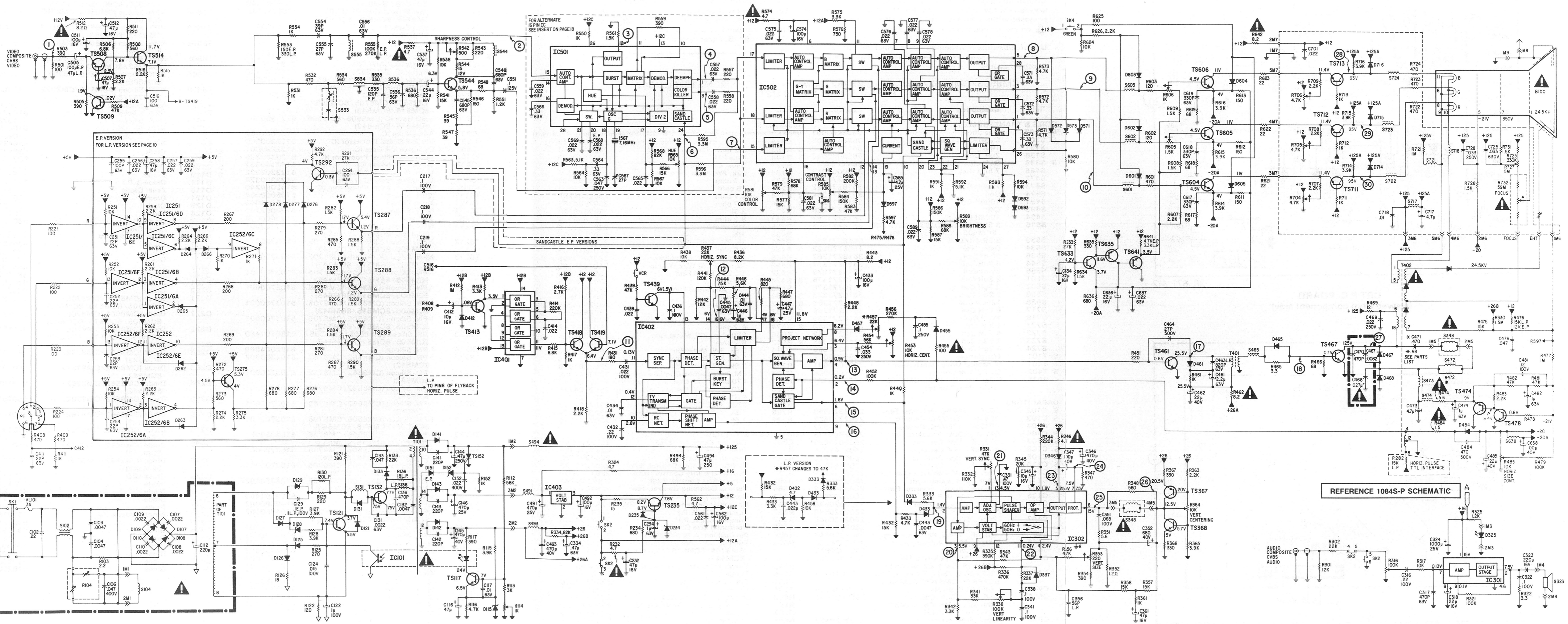

8CM542/CM8562/CM8762 RGB INTERFACE P.C. BOARD  
 (Early Production Version)  
 (viewed from component side)

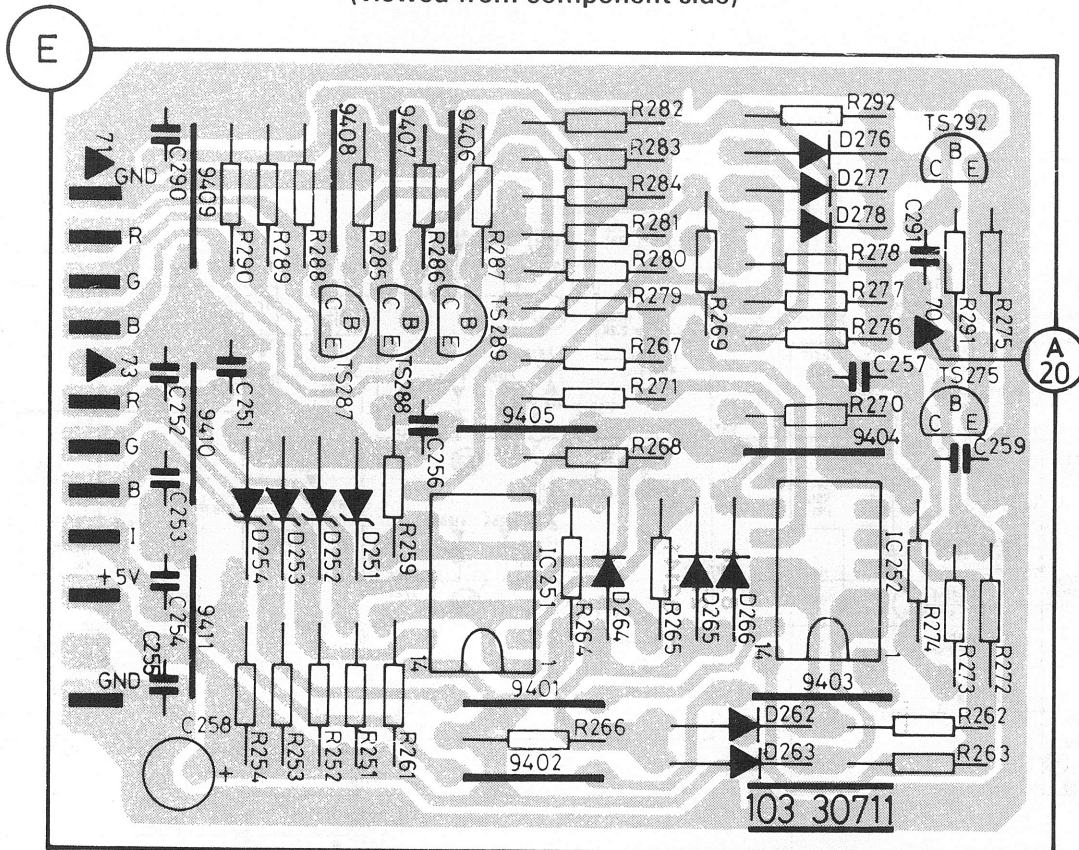

38 671 A12

CRT P.C. BOARD  
 (viewed from component side)

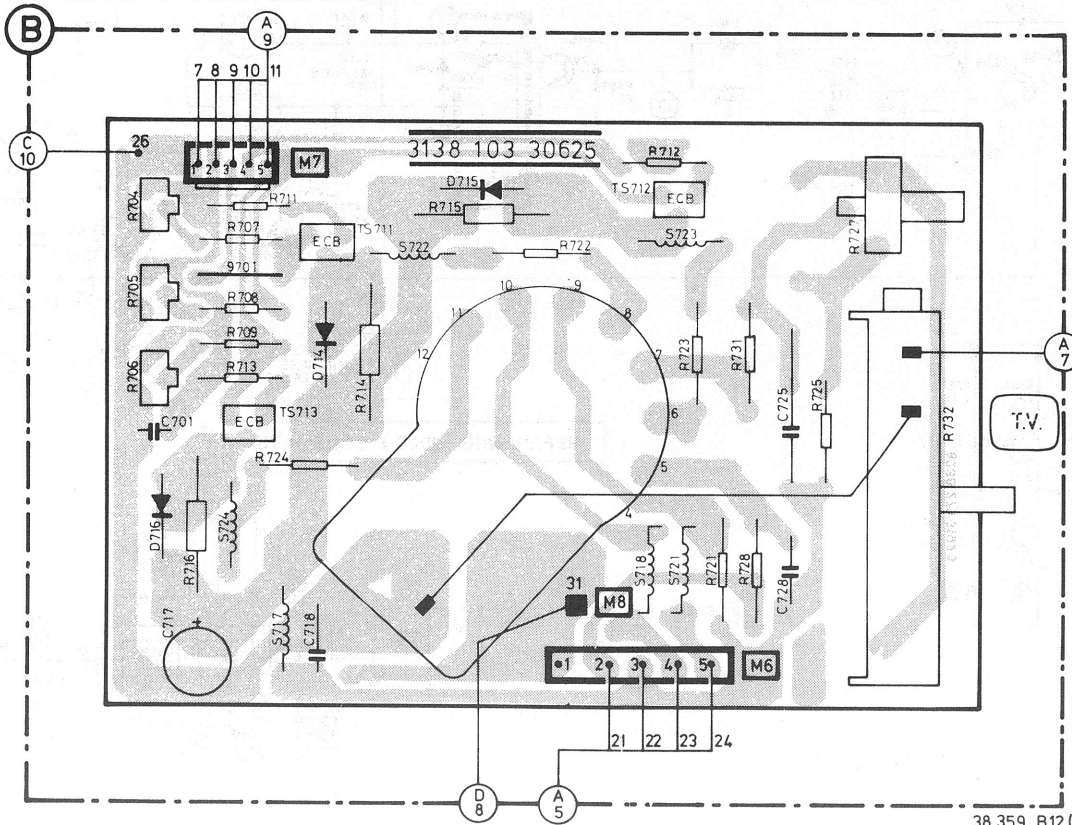

38 359 B12 (544)





Ref.	Description	Part No.	Ref.	Description	Part No.
<b>SEMICONDUCTORS (Continued)</b>			<b>MISCELLANEOUS (Continued)</b>		
D484	Diode	5391500450		Cabinet Foot, 4 used (CM8505/ CM8562)	1491030002
D571	Diode	5301811002		Cabinet Foot, 4 used (8CM505/ 8CM515/8CM643)	1491030003
D572	Diode	5301811002		Cover Adjustment (8CM542)	1491320214
D573	Diode	5301811002		Secondary Control Door (CM8505)	1492180011
D592	Diode	5301811002		Secondary Control Door (8CM505)	1492180010
D593	Diode	5301811002		Secondary Control Door (8CM515/ 8CM643)	1492180012
D597	Diode	5301811002		Secondary Control Door (CM8562)	1492180018
D601	Diode	5301811002		Text Plate (CM8505/CM8562)	1591060003
D602	Diode	5301811002		Text Plate (8CM505/8CM515)	1591060004
D603	Diode	5301811002		On/Off Pushbutton Knob (CM8505/CM8705)	1494200066
D604	Diode	5301811002		On/Off Pushbutton Knob (8CM505/8CM515/8CM643)	1494200074
D605	Diode	5301811002		On/Off Pushbutton Knob (CM8562/CM8762/8CM542)	1494200074
D714	Diode	5302681002		Pushbutton Knob (VCR SW., Comb Defeat (2 used))	1494200067
D715	Diode	5302681002		Pushbutton Knob (RGB/CVBS, Green (2 used))	1494200068
D716	Diode	5302681002		High Voltage Cable (CM8505/ CM8705/8CM505/8CM515/ 8CM643)	4613990214
<b>MISCELLANEOUS</b>				High Voltage Cable (CM8562/ CM8762/8CM542)	4613990221
S L101	Fuse, 3A	1813900214		Focus Cable	4613990213
S	Fuse Holder (2 used)	1035300932		Control Extender Rod (4 used)	1191000039
S B100	CRT w/Deflection Yoke (CM8505/CM8705)	A34EAJ00X		Owner's Manual (CM8505)	1B47290001
S B100	CRT w/Deflection Yoke (8CM505)	A34EAJ10X		Owner's Manual (8CM505)	1B47540001
S B100	CRT w/Deflection Yoke (8CM515)	M34EAQ00X		Owner's Manual (8CM515)	1B47550001
S B100	CRT w/Deflection Yoke (8CM542/8CM643)	E2971B55		Owner's Manual (8CM643)	1B50090001
S B100	CRT w/Deflection Yoke (CM8562/CM8762)	M34EAQ10X		Owner's Manual (CM8705)	1B53160001
S	CRT Socket	1892250011		Owner's Manual (CM8762)	1B53150001
S323	Speaker	5808350051		Owner's Manual (CM8562)	1B48180001
1567	Crystal	5699000028		Owner's Manual (8CM542)	1B52560001
	RCA Jack (2 used)	1813930160			
	6 Pin DIN Socket (CM8505/ CM8705/8CM505/8CM515/ 8CM643)	1814521073			
	8 Pin DIN Socket	1814521072			
	Cabinet (CM8505)	1492100002			
	Cabinet (8CM505)	1492100003			
	Cabinet (8CM515, 8CM643)	1492100004			
	Cabinet (8CM542)	1492900004			
	Cabinet (CM8562)	1492100005			

## NAPCEC SAFETY GUIDELINES FOR THE PROFESSIONAL SERVICE TECHNICIAN

### Safety Checks

After the original service problem has been corrected, a complete safety check should be made. Be sure to check over the entire set, not just the areas where you have worked. Some previous servicer may have left an unsafe condition, which could be unknowingly passed on to your customer. Be sure to check all of the following:

### Fire and Shock Hazard

1. Be sure all components are positioned in such a way as to avoid the possibility of adjacent component shorts. This is especially important on those chassis which are transported to and from the service shop.
2. Never release a repaired receiver unless all protective devices such as insulators, barriers, covers, strain reliefs, and other hardware have been installed according to the original design.
3. Soldering and wiring must be inspected to locate possible cold solder joints, solder splashes, sharp solder points, frayed leads, pinched leads, or damaged insulation (including ac cord). Be certain to remove loose solder balls and all other loose foreign particles.
4. Check across-the-line components and other components for physical evidence of damage or deterioration and replace if necessary. Follow original layout, lead length and dress.
5. No lead or component should touch a receiving tube or a resistor rated at 1 watt or more. Lead tension around protruding metal surfaces or edges must be avoided.
6. Critical components having special safety characteristics are identified with an S by the Ref. No. in the parts list and enclosed within a broken line\* along with the safety symbol  on the schematics. Replacement parts without the same safety characteristics may create shock, fire or other hazards.
7. When servicing any receiver, always use a separate isolation transformer for the chassis. Failure to use a separate isolation transformer may expose you to possible shock hazard, and may cause damage to servicing instruments.
8. Many receivers use a polarized line cord (one wide pin on the plug). Defeating this safety device may create a potential hazard to the servicer and the user. Extension cords which do not incorporate the polarizing feature should never be used.
9. After re-assembly of the set, always perform an ac leakage test or resistance test from the line cord to all exposed metal parts of the cabinet. Also, check all metal control shafts (with knobs removed), antenna terminals, handles, screws, etc. to be sure the set is safe to operate without danger of electrical shock.

\* Broken line: 

### Implosion

1. All picture tubes used in current model receivers are equipped with an integral implosion system. Care should always be used, and safety glasses worn, whenever handling any picture tube. Avoid scratching or otherwise damaging the picture tube during installation.
2. Use only replacement tubes as specified by the manufacturer.

### X-radiation

1. Be sure procedures and instructions to all your service personnel cover the subject of X-radiation. Potential sources of X-rays in TV receivers are the picture tube and the high voltage circuits. The basic precaution which must be exercised is to keep the HV at the factory recommended level.
2. To avoid possible exposure to X-radiation and electrical shock, only the manufacturer's specified anode connectors must be used.
3. It is essential that the service technician has available at all times an accurate HV meter. The calibration of this meter should be checked periodically against a reference standard.
4. When the HV circuitry is operating properly there is no possibility of an X-radiation problem. High voltage should always be kept at the manufacturer's rated value — no higher — for optimum performance. Every time a color set is serviced, the brightness should be run up and down while monitoring the HV with a meter to be certain that the HV does not exceed the specified value and that it is regulated correctly. We suggest that you and your service technicians review test procedures so that HV and HV regulation are always checked as a standard servicing procedure, and the reason for this prudent routine be clearly understood by everyone. It is important to use an accurate and reliable HV meter. It is recommended that the HV reading be recorded on each customers' invoice, which will demonstrate a proper concern for the customers' safety.
5. When troubleshooting and making test measurements in a receiver with a problem of excessive high voltage, reduce the line voltage by

means of a Variac to bring the HV into acceptable limits while troubleshooting. Do not operate the chassis longer than necessary to locate the cause of the excessive HV.

6. New type picture tubes are specifically designed to withstand higher operating voltages without creating undesirable X-radiation. It is strongly recommended that any shop test fixture which is to be used with the new higher voltage chassis be equipped with one of the new type tubes designed for this service. Addition of a permanently connected HV meter to the shop test fixture is advisable. The CRT types used in these new sets should never be replaced with any other types, as this may result in excessive X-radiation.
7. It is essential to use the specified picture tube to avoid a possible X-radiation problem.
8. Most TV receivers contain some type of emergency "Hold Down" circuit to prevent HV from rising to excessive levels in the presence of a failure mode. These various circuits should be understood by all technicians servicing them, especially since many hold down circuits are inoperative as long as the receiver performs normally.

### Leakage Current Cold Check

1. Unplug the ac line cord and connect a jumper between the two prongs of the plug.
2. Turn on the power switch.
3. Measure the resistance value between the jumpered ac plug and all exposed cabinet parts of the receiver, such as screw heads, antennas and control shafts. When the exposed metallic part has a return path to the chassis, the reading should be between 1 megohm and 5.2 megohms. When the exposed metal does not have a return path to the chassis, the reading must be infinity. Remove the jumper from the ac line cord.

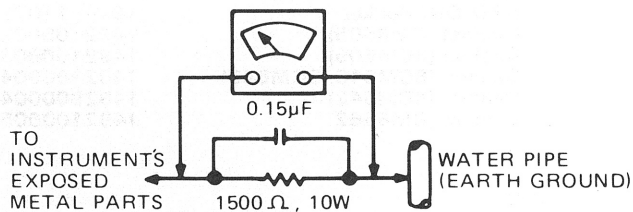

### Leakage Current Hot Check

1. Do not use an isolation transformer for this test. Plug the completely re-assembled receiver directly into the ac outlet.
2. Connect a 1.5k ohm, 10 watt resistor paralleled by a 0.15µF. capacitor between each exposed metallic cabinet part and a good earth ground such as a water pipe, as shown above.
3. Use an ac voltmeter with at least 5000 ohms/volt sensitivity to measure the potential across the resistor.
4. The potential at any point should not exceed 0.75 volts. A leakage current tester may be used to make this test; leakage current must not exceed 0.5 milliamps. If a measurement is outside the limits specified, there is a possibility of shock hazard. The receiver should be repaired and re-checked before returning it to the customer.
5. Repeat the above procedure with the ac plug reversed. (Note: An ac adapter is necessary when a polarized plug is used. Do not defeat the polarizing feature of the plug.)

### Picture Tube Replacement

The primary source of X-radiation in this television receiver is the picture tube. The picture tube utilized in this chassis is specially constructed to limit X-radiation emissions. For continued X-radiation protection, the replacement tube must be the same type as the original, including suffix letter, or an N.A.P. Consumer Electronics Corp. (NAPCEC) approved type.

### Parts Replacement

Many electrical and mechanical parts in NAPCEC television sets have special safety-related characteristics. These characteristics are often not evident from visual inspection nor can the protection afforded by them necessarily be obtained by using replacement components rated for higher voltage, wattage, etc. The use of a substitute part which does not have the same safety characteristics as the NAPCEC recommended replacement part shown in this service manual may create shock, fire or other hazards.

## COMMODORE STOCKED PARTS — 1084S-P

CBM PART NUMBER	DESCRIPTION	LOCATION	PHILIPS OEM NUMBER
314890-01	SERVICE MANUAL 1084		
314851-01	CABLE 1084 (6 to 23)		
610200-11	LINE CHOKE	S102	3693400001
610200-12	DEGAUSSING COIL	S104	3693100005
610200-13	DEFLECTION YOKE (PART OF CRT)	S348	—
610200-14	TRANSFORMER	T101	3090200003
610200-15	HORZ DRIVE TRANSFORMER	T401	3293000001
610200-16	OUTPUT TRANSFORMER	T402	3291000006
610200-17	CAP .0082 $\mu$ F, 1.5KV POLY FILM	C467	2602320549
610200-18	CAP .022 $\mu$ F, 400V POLYPROP	C468	2602320597
610200-19	DUAL PTC	R104	4H11640035
610200-20	FOCUS CONTROL, 59M	R732	2204290730
610200-21	POWER SWITCH	SK1	1606780548
610200-22	IC OPTIC COUPLER	IC101	5303110001
610200-23	IC AUDIO AMP	IC301	6123300289
610200-24	IC VERT SIGNAL PROCESSOR	IC302	6123300289
610200-25	IC HORZ SIGNAL PROCESSOR	IC402	6123300330
610200-26	IC VIDEO PROCESSOR (28 PIN)	IC501	6123300332
610200-27	IC VIDEO AMP	IC502	6192080240
610200-28	TRANSISTOR NPN TS461	TS461	6105350003
610200-29	TRANSISTOR NPN TS467	TS467	6104330001
610200-30	TRANSISTOR NPN TS711, 712, 713	TS711	6104390001
610200-31	DIODE D107, 108, 109, 110	D107	5391200341
610200-32	CRT WITH DEFLECTION YOKE	B100	M34EAQ10X
610200-33	CRT SOCKET	—	1892250011
610200-34	CABINET (CM8562)	—	1492100005
610200-35	CONTROL PANEL DOOR	—	1492180018

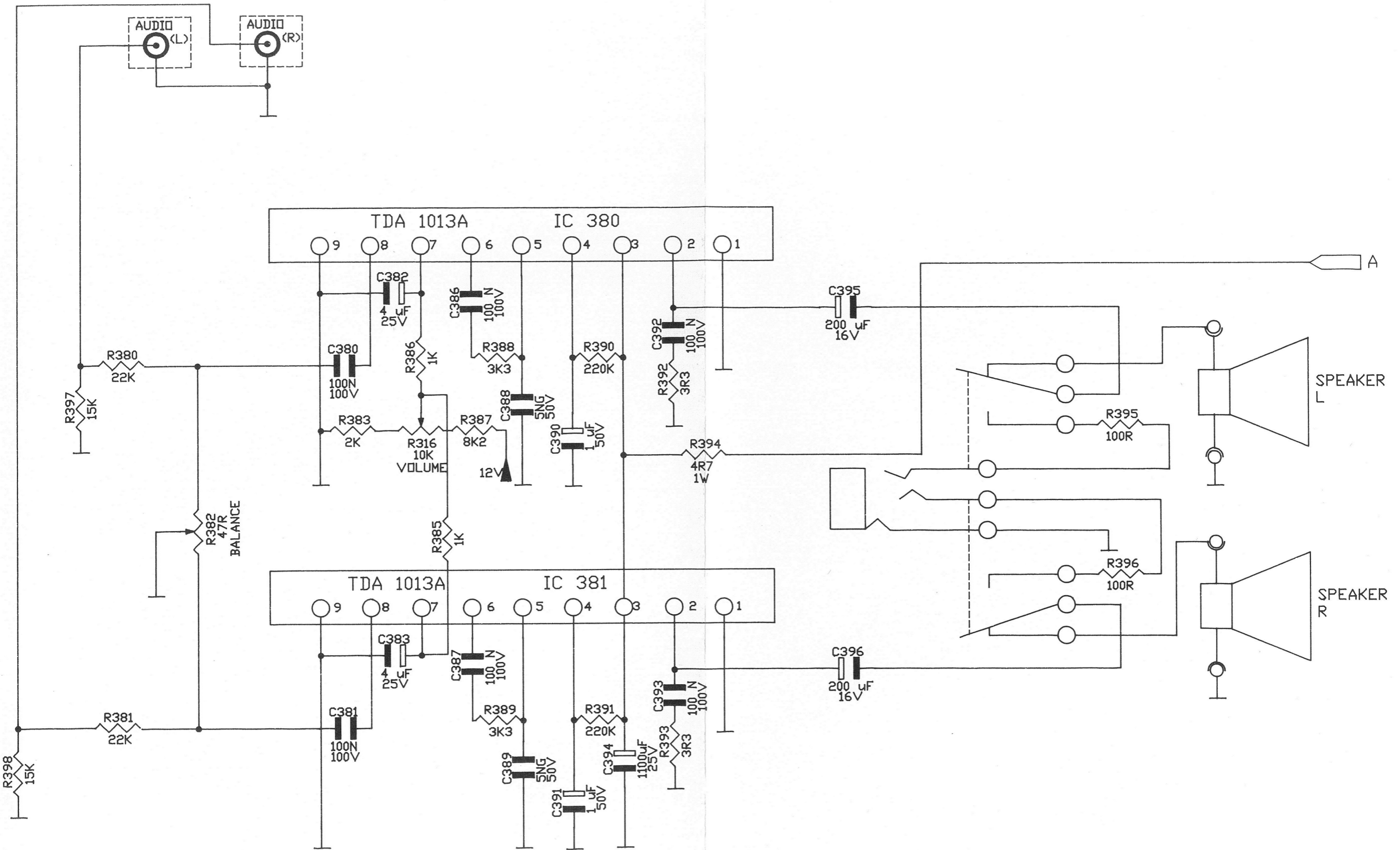

1084S-P  
SCHEMATIC



Computer Systems Division  
1200 Wilson Drive  
West Chester, PA 19380